

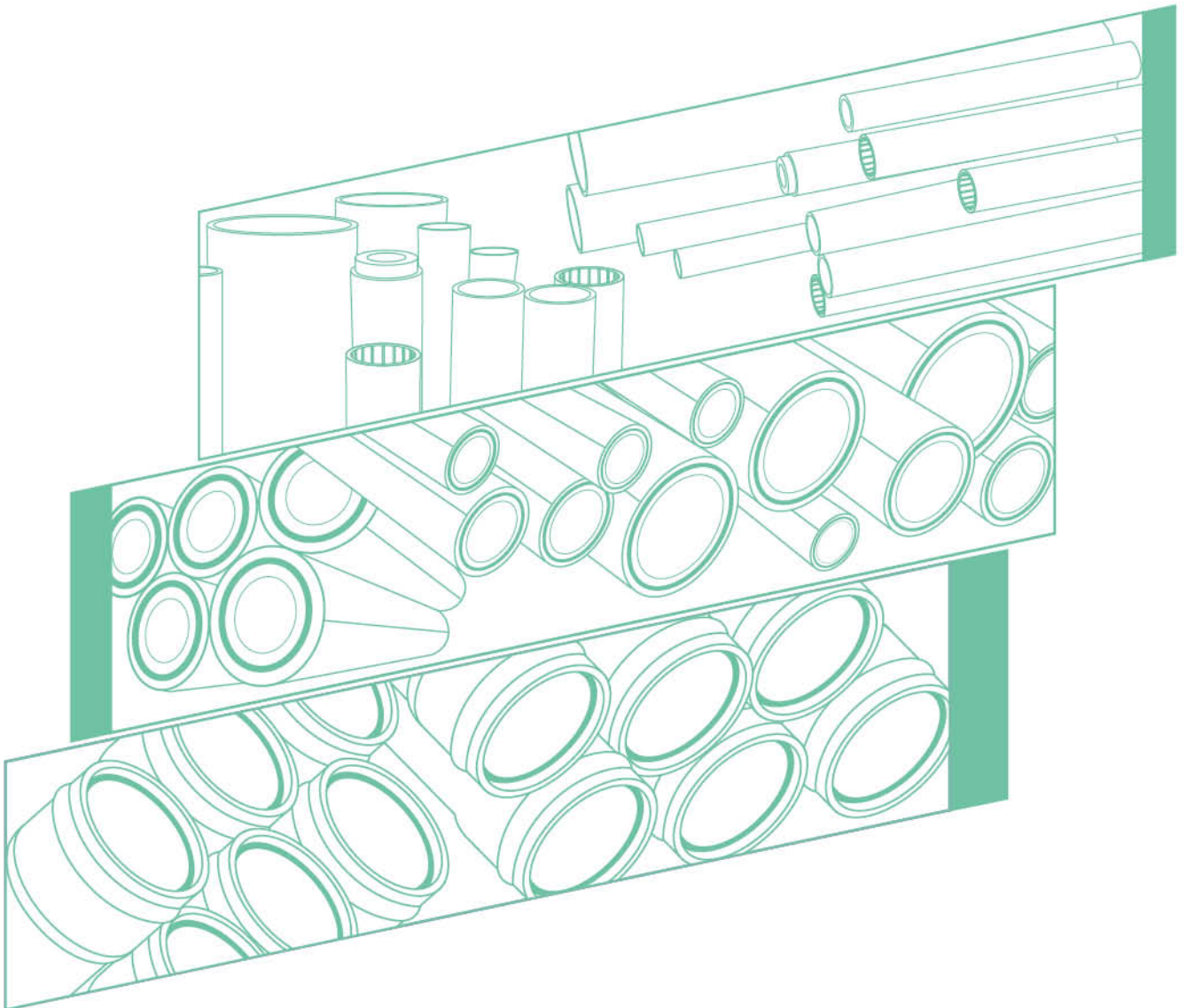

Everplast

PIPE EXTRUSION MACHINE



we offer turnkey and total solution



PIPE PRODUCTION LINE

This portion of the production line introduces pipe extrusion, which uses materials such as PVC, HDPE, LDPE, PE, PP, ABS, PS, PC and PMMA to extrude products in accordance with market needs and the special characteristics of the plastic materials.

Products manufactured with these machines include construction materials, toys and stationery, furniture and furnishings, medical supplies, lighting decorations and electrical accessories.

Since its founding EVERPLAST Machinery's production line has turned out more than 1500 extruding systems of this type. These machines turn out products that are well suited to the market and features design that is directly related to the characteristics of the production processes that are exactly right for the plastic materials being used.

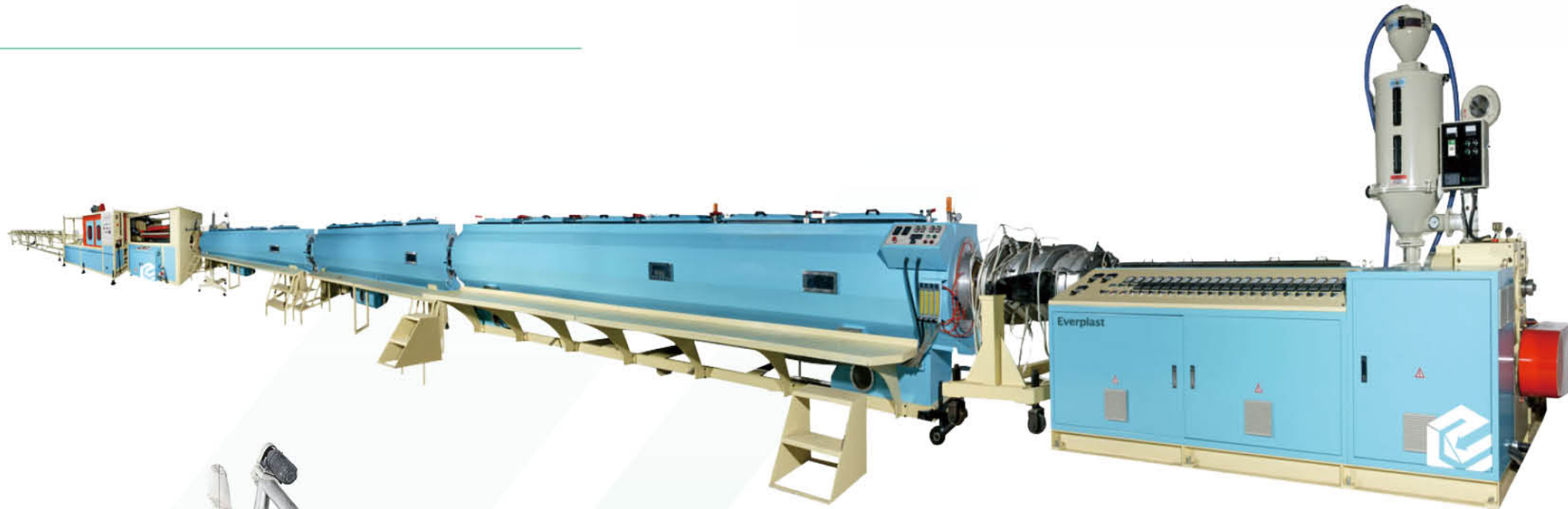
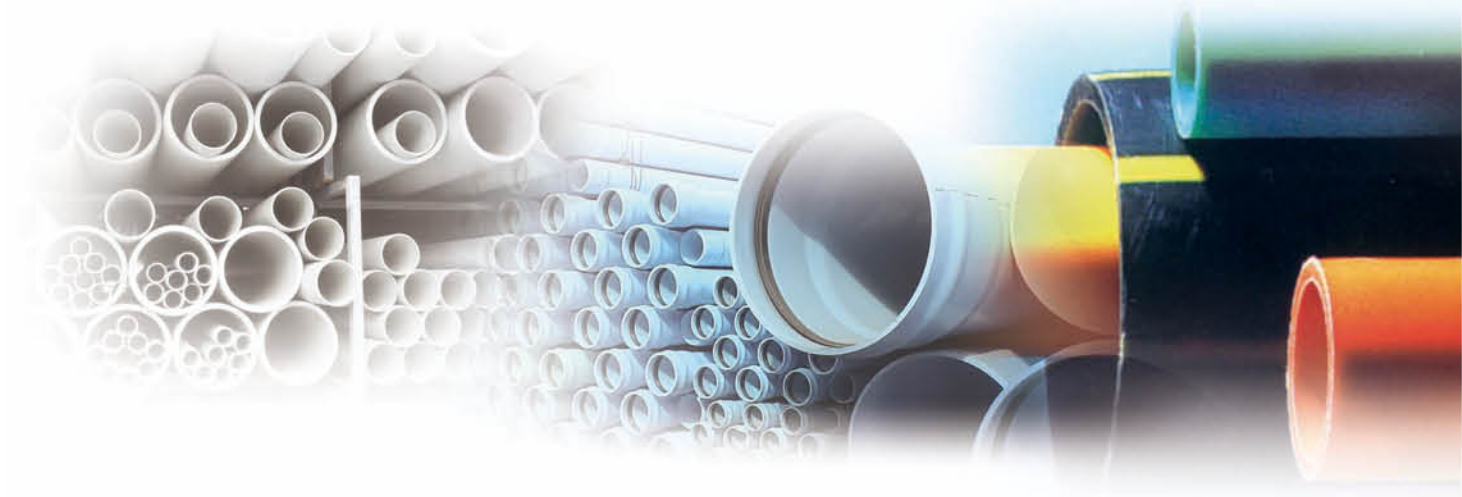

PE / PP Pipe Line



PVC Pipe Line

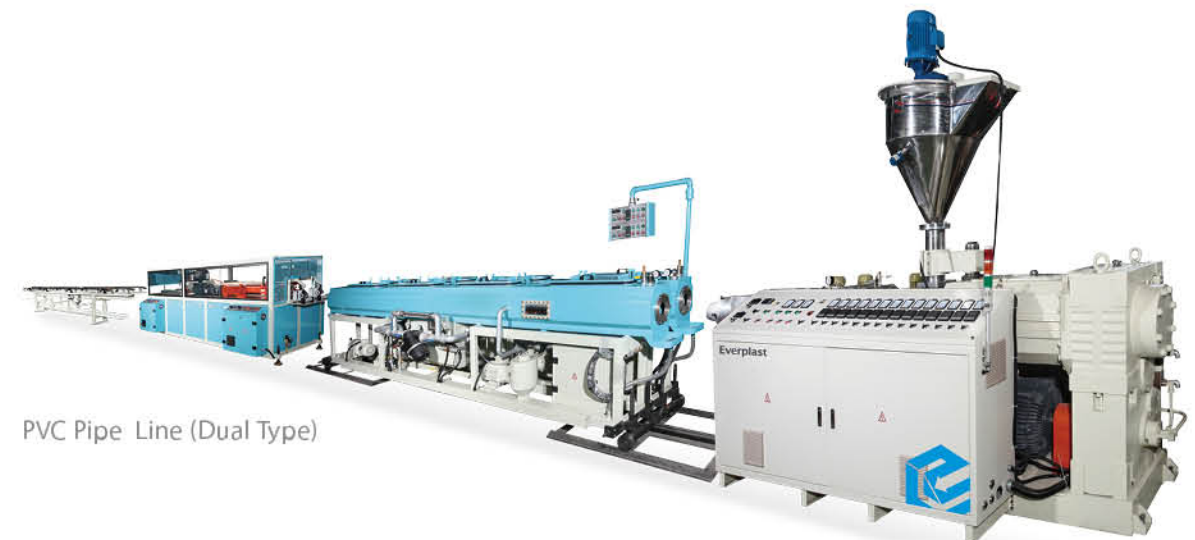

PVC Pipe Line (Dual Type)

➤ EXTRUDING MACHINE

EMS / EMD Series

- PVC counter rotating twin extruder for pipe, in sizes EMD-65, EMD-90, EMD-110 and EMD-130 to meet a wide range of requirements.
- Single screw extrudes available in models EMS-45, 65, 85, 100 and 120 to meet a wide range of requirements in various materials meet PVC pipe size: $\phi 12\text{mm}$ to $\phi 310\text{mm}$.
- HDPE single screw extruder models EMS-45H, EMS-65H, EMS-85H, EMS-100H and EMS-120H, to produce from $\phi 12\text{mm}$ to $\phi 310\text{mm}$. HDPE pipe with output from 30-700 KGS/HR.
- Precision ground gears deliver a driving force that is more than 98 percent accurate with noise levels of less than 65dB.
- "PID" thermo controller with "SCR" output temperature systems are used throughout to minimize power consumption and maintain temperature levels which are within one degree of set temperatures.
- Along with cast aluminum cooling device on the barrel, and high efficiency of drive motor and gears. That ensure consistent products and high outputs.
- Optional extras:
 - Computer controller system.
 - P.T.A treatment for screw.



EMD-C-65 Conical Twin Screw Extruder



EMD-C-80 Conical Twin Screw Extruder



EMD-90 Conical Twin Screw Extruder



EMD-130 Conical Twin Screw Extruder

Single / Twin Extruder



EMS-100 + EMS-55 + EMS-45
Single Screw Extruder



Vertical Co-Extruder

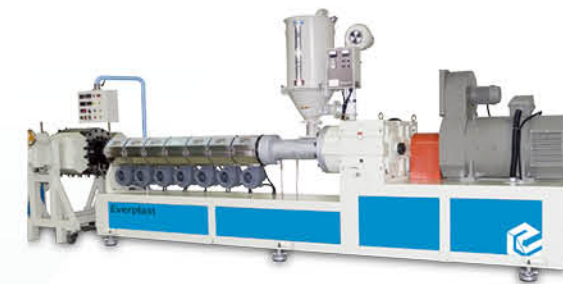

EMS-100 Single Screw Extruder



EMS-100 Single Screw Extruder



EMS-60 Single Screw Extruder



EMS-65 Single Screw Extruder (Movable Type)



EMS-65 Single Screw Extruder



EMS-85 Single Screw Extruder

➤ MULTI-SPRAY NOZZLES COOLING SYSTEM

16" Double Chamfer Vacuum Spray Cooling Tank



EPST-206



EPST-302



EPST-816 Vacuum Spray Water Cooling Tank



1200mm Vacuum Spray Cooling Tank



EPST-304



EPST-405



10" Vacuum Spray Cooling Tank



EPST-412



EPST-602

EPST Series

The EPST series uses pipe ranging from 3/8" to 12" in diameter. Positions can be adjusted front and back or left and right. Front-back movements is done by a stepless inverter motor which can make either high-speed or incremental adjustments. A cooling spray system which can get very good cooling efficiency of extruded products within ±1%. Closed system design keeps water temperature levels within a fixed range, and coolant water is drained only when it exceeds setting temperature, to minimize water use and save energy cost. Vacuum pressure in the tank can be adjusted to suit the characteristics of different plastic materials.



EPST-604

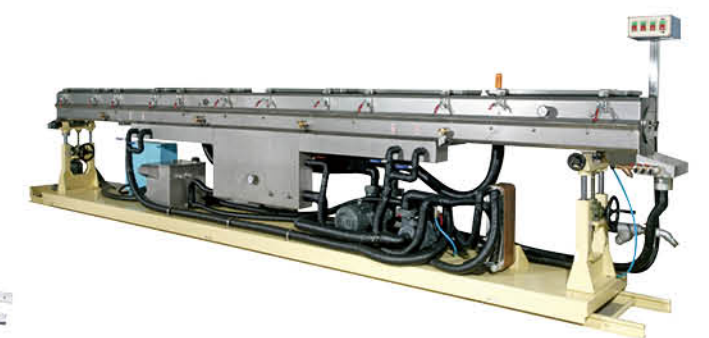

EPST-604

> MULTI-SPRAY NOZZLES COOLING SYSTEM



120mm Water Cooling Tank



8" Spray Cooling Tank



EPST-602-2 Vacuum Spray Water Cooling Tank (Dual Type)



4" Vacuum Spray Cooling Tank



EPST-608D Vacuum Spray Water Cooling Tank



2" Vacuum And Cooling Tank



EPST-603-2 Vacuum Spray Water Cooling Tank (Dual Type)



EPST-605



EPST-605D



EPST-608



EPS-605D



EPST-605D+EPST-605+EPS-605

HAUL-OFF MACHINE

ETB.ETC Series

- Speed varies from 0.1M/MIN to 100 M/MIN.
- Diameters range from ø1MM to ø450MM.
- High-sensitivity clamps effectively meet the needs of every type of products.
- Auto pressure balance system responds to varying shapes of products to avoid production shutdowns when shapes are changed.
- Microcomputer counter can be used to set the length of products and count the pieces of products.
- Design of the large Haul off machine includes thick, harden glass sliding doors which provide a clear view of the production process with a high degree of safety. They also facilitate maintenance and repair easily.
- Compound tracks use UHMW-PE which is outstanding wear resistance and monimal pollution, and rubber of caterpillar are special flush design which is changed easily.
- Four-tracks and six-tracks haul-off machine are also available.



ETB-0360 Haul-Off Air Cutter+Stacker



Dancer + Haul-Off +Air Cutter+Stacker



X.Y Tube Dia. Detector+Belt Haul Off +Fly Cutter



Double Haul-Off Unit



Twist Belt Haul-Off



Height Adjustable



Center Adjustable



ETB-06 Series Belt Type



ET4C 4 Tracks Clamping Haul-Off Unit



ET6C 6 Tracks Clamping Haul-Off Unit+ Hot Stamping



ETC-05 Series Caterpillar Type



Vertical And Horizontal Guider



Belt + Air Cutter



ETC-15 Series Caterpillar Type

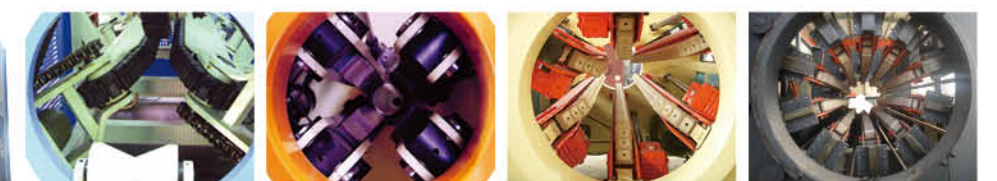

3 Tracks Clamping Haul-Off Unit 4 Tracks Clamping Haul-Off Unit 6 Tracks Clamping Haul-Off Unit 10 Tracks Clamping Haul-Off Unit

ETC- 10 10 Tracks Clamping Haul-Off Unit (Max. 1200mm)

> CUTTING SYSTEM



ESC-14/16/18/20 Saw Cutter



Saw Cutter + Stacker



ERK-250 Rotary Cutter



EFC.ERC.ERK.ERS.ESC Series

- EFC series uses a flying blade with intermittent action to cut soft and thin thickness tube and small pipe.
- ERC series features simultaneous cutting and chamfering in a 360-degree motion for cutting soft and thin thickness pipe.
- ERK series uses two opposing blades in a 360-degree motion for simultaneous chamfering and cutting of rigid pipe.
- ERS series features rotary saw encircling the extruded tubing with 360-degree motion for simultaneous chamfering and cutting.
- ESC series utilizes rotary saw moving upward to cut harder materials.



Air Cutter (Quickly Type)



Saw Cutter



Cosmetic Tube Fly Cutter



Fly Cutter Knife



Belt Haul Off + Fly Cutter



20-63 Dural Cutter Machine



ERC-400 Cutting Machine



Planetary Cutter with Chamfer



Planetary Cutter



Planetary Cutter

> WINDER

EVERPLAST winder (coiler) suitable for winding small tube, such as PU tube, medical tube garden hose, medium and big size pipes, such as pipes, PE, PEX, PVC hoses, rubber pipes....etc.

- We offer the Single Bobbin Winder, Two Bobbins Winder, also Four Bobbins Winder.
- Dancer (tension control) control the tube speed and tension synchronized with winder.

Semi-Automatic Single Bobbin Winder



Single Bobbin Winder



Dancer+ Two Bobbin Winder + Air Cutter



Double Bobbin Winder



1200MM Single Bobbin Winder



Dancer + Single Bobbin Winder



EWD-800E Double Bobbin Winder



EWD-1500 Single Bobbin Winder

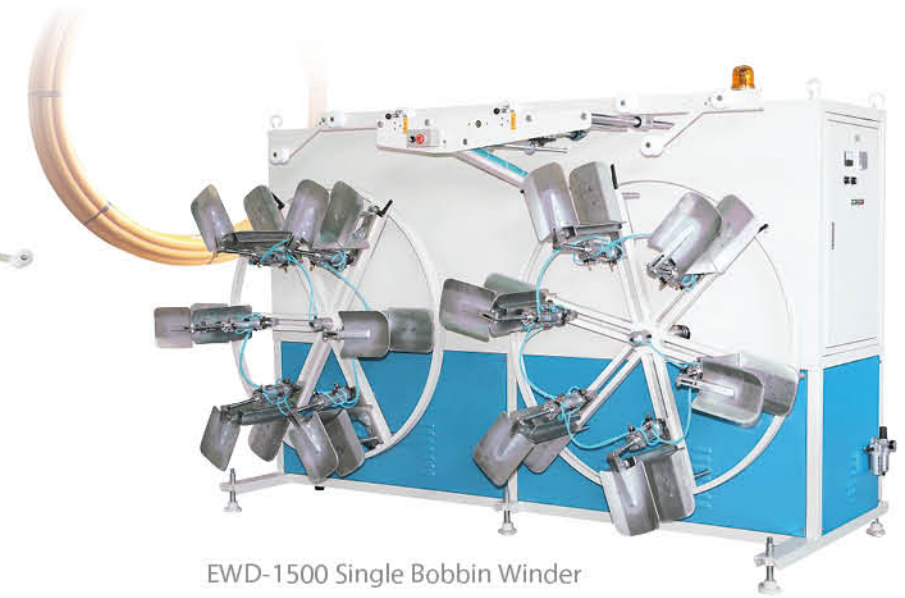

EWD-3200 Single Bobbin Winder



EWD-1500 Double Bobbin Winder



EWD-700 Four Bobbin Winder + Dance



EWD-1500 1500MM Single Bobbin Winder



> STACKER



PIPE Stacker



PROFILE Stacker



PIPE Stacker



PIPE Stacker (Dual Type)



PIPE Stacker



PIPE Stacker

> GEAR BOX / SCRAW BARRLE



Single Screw



Counter - Rotation Twin Screw



Conical Twin Screw and Barrel



Twin Gear Box for Conical Screw



> DIE / DIE CARRIER / SIZING SLEEVE

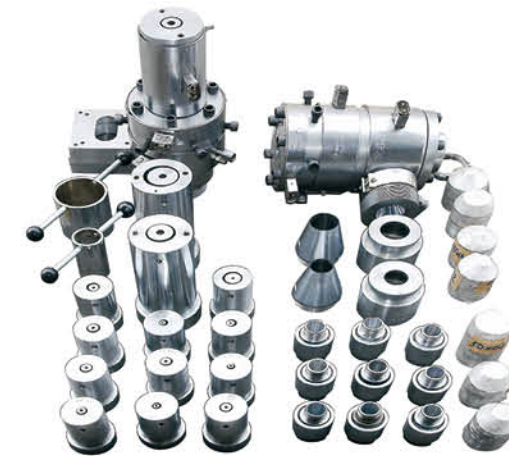

Sizing Sleeve



Co-Extruder Die



Spiral Dia



355 mm Die Carrier



> BELLING MACHINE

200 Automatic Belling Machine



250 Double Pipe Automatic Belling Machine

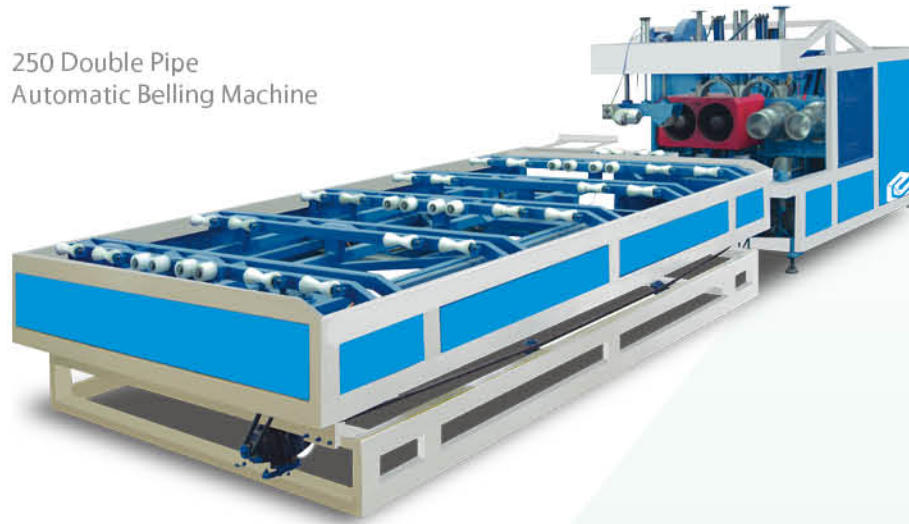

250 Semi-Automatic Belling Machine



> HOT PRINTING MACHINE



> PLASTIC-PIPE HYDRAULIC PRESSURE TESTING MACHINE



- Application
Used for testing bursting transient pressure and static pressure of the plastic pipe and composite pipe such as PVC, PE, PP, ABS, PEX
- Controlled Pressure Unit
Still have the function of parameter setting, rest time supervision without a break, and test report printed output.
- Constant Temp. Tank
Room temp. to 95°C or 15 to 95°C
ø16mm to 630mm



WELDING MACHINE

Application and Features:

Application to fabricate PE, PP, PVDE elbow, tee, cross fittings in workshop.
Also used to lengthen the injection molded fitting and make the integrated fittings.

Optional parts:

- Special clamps for welding flange stub.
- Special clamps for short spigot fitting.
- Special clamps for welding Y shape (45° and 60°) fittings



315mm
Welding Machine

450-630mm
Welding Machine



630mm Welding Machine

800-1200mm Welding Machine

MULTI-ANGLE CUTTING MACHINE

Application and Features:

Suitable for cutting pipes according to specified angle and dimension while making an elbow tee or cross, which lowest the material waste and improve the welding efficiency. Cutting angle 0~67.5°



630mm Cutting Machine

Specification	Type	Twin Screw Extruder															
		Parallel Twin Screw Extruder						Concial Twin Screw Extruder									
		EMD-65		EMD-90		EMD-110		EMD-130		EMD-55C		EMD-65C		EMD-80C		EMD-92C	
Screw Length (L/D)		25/28	25/28	22	22	22	22	22	22	22	22	22	22	22	22	22	22
Screw Diameter (MM)		65×2	90×2	110×2	130×2	55/112	65/132	80/156	92/188								
Screw Speed (R.P.M)		60	44	38	30	40	40	40	40								
Dirve Motor Power (HP)		--	30	60	75	90	100	125	150	30	50	75	150				
Cylinder Heating (KW)		--	22	30	38	42	50	80	90	16	22	39	53				
Flange Heating (KW)		5	6	7.5	8.5	2	4	4	8								
Cylinder Cooling Power (KW)		0.6	0.6	1.2	1.2	1.5	1.5	1.5	2								
Installed Electric Power (KW)		40/51	82/102	119/133	175/192	48	67	102	160								
Number Of Die Heating Zones		2+3	2+4	2+4	2+4	2	4	8	10								
Number Of Cylinder Heating Zones		4	4	4	5	4	4	4	4								
Hopper Sizes (KG)		100	150	200	200	75	100	150	150								
Center Height (MM)		1100	1100	1100	1100	1100	1100	1100	1100								
Weight (KG)		2000	3000	4100	5600	2300	3600	3900	4800								
M.A.X Output (KG/HR)	HDPE (PIPE)	--	--	--	--	--	--	--	--								
	PVC Soft	--	--	--	--	--	--	--	--								
	PVC Hard	120	160	400	500	600	700	800	1000	60~120	80~150	250~360	450~600				

Specifications are subject to change without notice.

> SPECIFICATION

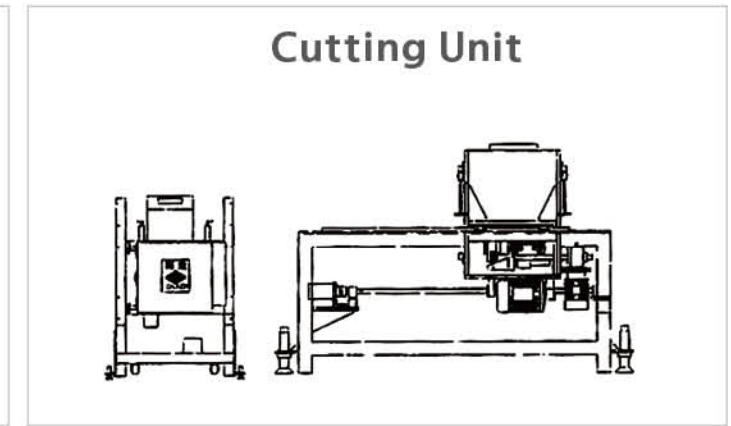
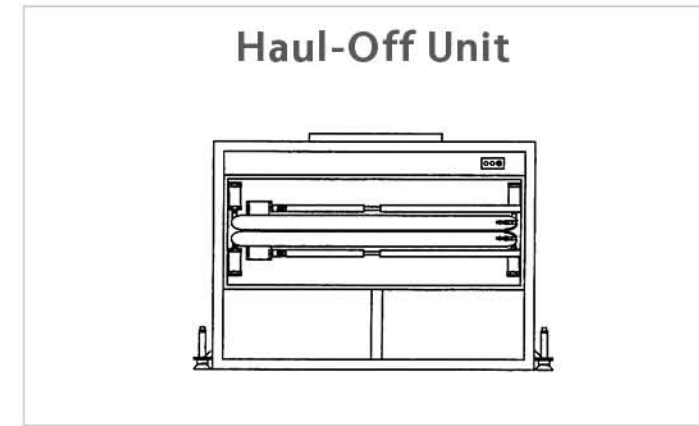
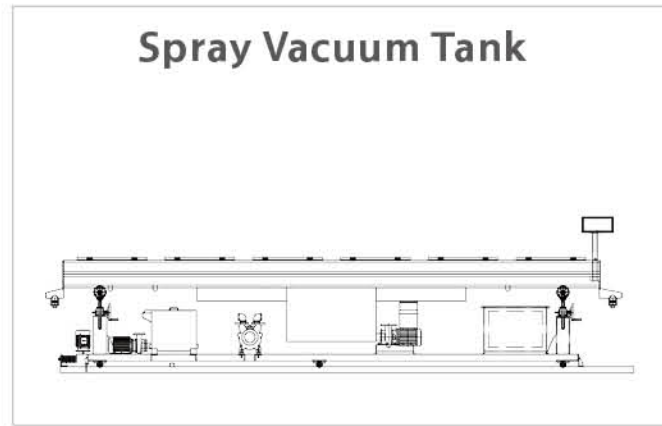
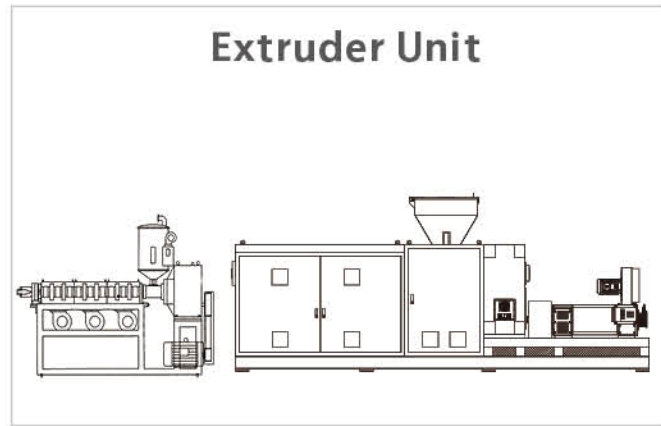

Specification	Type	General Single Extruder					High Efficiency Single Extruder				
		EMS-45	EMS-65	EMS-85	EMS-100	EMS-120	EMS-150	EMS-6533H	EMS-7533H	EMS-9033H	EMS-120-33H
Screw Length (L/D)		24/28	24/28	24/28	24/28	24/28	24/33	33	33	33	33
Screw Diameter (MM)		45	65	85	100	120	150	65	75	90	120
Screw Speed (R.P.M)		60	60	45	40	35	60-100	150	150	120	100
Dirve Motor Power (HP)		15	30/75	60/125	100/200	125/350	400	125	200	300	400
Cylinder Heating (KW)		7.5	12	14	15	22	40	18	24	38	59
Flange Heating (KW)		0.5	0.7	1	1	1	2	2	2	3	4
Cylinder Cooling Power (KW)		0.75	1.5	2.5	3.25	5	7	2	2.5	2.5	3
Installed Electric Power (KW)		22	36	47	88	110	450	126	190	283	375
Number Of Die Heating Zones		2	3	3	4	4	5	6	8	10	12
Number Of Cylinder Heating Zones		3	3	4	5	6	7	5	6	6	8
Hopper Sizes (KG)		50	50	100	100	100	150	50	50	100	200
Center Helght (MM)		1100	1100	1100	1100	1100	1100	1100	1100	1100	1100
Weight (KG)		850	1100	1600	2200	3500	4000	2800	4100	5100	6300
M.A.X Output (KG/HR)	HDPE (PIPE)	25	60/150	100	200/400	250/500	1000	230	350	500	800
	PVC Soft	50	75	130	180	--	--	--	--	--	--
	PVC Hard	35	60	110	150	--	--	--	--	--	--

Specifications are subject to change without notice.

>Figure of Haul-Off

Specification	Type	Belt		Caterpillar					
		ETB-05	ETB-10	ETC-05	ETC-10	ET-4C	ET-6C	ET-8C	ET-10C
Pipe Diameter From/to (MM)		0-110	0-110	0-110	0-110	60-250	125-450	630-1000	630-1200
Number Of Caterpillars		2	2	2	2	4	6	8	10
Contact Length (MM)		350	750	350	750	1800	2400	2400	2400
MAX. Pulling Force (N)		3400	6000	3400	6000	7800	20000	25000	25000
MAX. Line Speed (M/MIN)		50	20	12	9	9	6	0.2-1	0.2-1
Drive Motor (KW)		1.5	2.25	1.5	2.25	3.75	5	10	10
Installed Electric Power (KW)		2	3	2	3	5	6.5	7.5	7.5
Weight (KG)		550	1200	600	1000	1300	1800	2000	2500

Specifications are subject to change without notice.

>Figure of Spray Vacuum Tank For Pipe

Specification	Type	EPST-154	EPST-304	EPST-308	EPST-608	EPST-3012	EPST-6012
MAX. Diameter (MM)		125	125	250	250	450	450
Length Of Vacuum Tank (MM)		1500	3000	3000	6000	3000	6000
Vacumm Pump Power (KW)		2.25×1	2.25×1	2.25×1	3.75×1	3.75×1	3.75×2
Spray Pump Power (KW)		1.5	1.5	2.25	3.75	3.75	5
Number Of Spray Nozzles		52	104	104	208	104	208
Guide Rollers		1	2	2	3	2	4
Installed Electric Power (KW)		5.5	6.25	7.5	11.25	10.5	17
Drainage Pump Power (KW)		0.4	0.4	0.75	0.75	1.5	1.5
Inflow Pipe Diameter (IN)		1	1	1	1.5	1.5	1.5
Exhaust Outlet Pipe Diameter (OUT)		1	1.5	1.5	2	2	2
Weight (KG)		700	1100	1300	1700	1400	2400
Adjustable Length For Back And Forward (MM)		750	750	750	750	750	750
Adjustable Length For Right Aad Left (MM)		25	25	25	25	25	25
Adjustable Length For Up And Down (MM)		50	50	50	50	50	50

Specifications are subject to change without notice.

>Figure of Cutter

Specification	Type	Saw Cutting				Knife / Chamfer Cutter					Fly Cutter		
		ESC-14	ESC-16	ESC-18	ESC-20	ERK-50	ERK-114	ERK-160	ERK-216	ERK-318	EFC-30	EFC-60	
Cutting Motor (KW)		0.5	0.5	1.5	1.5	0.35	0.75	2.25	2.25	2.25	1.5	2.25	
MIN. Pipe Dia(MM)		10	10	10	10	18 (3/8")	48 (1-1/2")	60 (2")	110 (4")	216 (8")	1	1	
MAX. Pipe Dia(MM)		90	115	155	180	60 (2")	114 (4")	160 (6")	216 (8")	318 (12")	30	60	
MAX. Wall Thickness (MM)		--	--	--	--	5	7	8.5	10.5	13	--	--	
Cutting MAX. Speed (M/MIN)		12	10	8	6	1~12	1~6	1~6	1~4	1~4	100	100	
Cutting Type		Saw				Knife / Chamfer Cutter					Knife		
Center Height 50(MM)		1050/1100	1050/1100	1050/1100	1050/1100	1050/1100	1050/1100	1050/1100	1050/1100	1050/1100	1050/1100	1050/1100	
Chamfer (20-30)		no	no	no	no	yes	yes	yes	yes	yes	no	no	
Net Weight (KG)		320	320	400	420	850	900	1200	1900	2500	160	170	
Suitable Products (KG)		PVC. PS.ABS. HDPE. (PIPE)					PVC. PS.ABS (PIPE)					SOFT. TUBE	

Specifications are subject to change without notice.

› **MAIN PIPE EXTRUSION LINES AVAILABLE:**

- 1.HDPE/LDPE PIPE RANGE TO MAX.Ø1200 m/m
- 2.PVC PIPE RANGE TO MAX.Ø1200 m/m
- 3.LDPE COSMETIC TUBE
- 4.PU PRECISION TUBE
- 5.HDPE STEEL PIPE COATING SYSTEM
- 6.PC TRANSPARENT TUBE
- 7.FLEXIBLE PVC TUBE AND REINFORCED HOSE
- 8.RIGID / SOFT PVC SUCTION HOSE
- 9.PVC MEDICAL TUBE
- 10.PVC / PE DIE UPTO Ø1200 m/m

› **MAIN PROFILE EXTRUSION LINES AVAILABLE:**

- 1.WOOD PLASTIC COMPOSITE
- 2.PVC FOAM PROFILES
- 3.PVC WINDOW / DOOR COMPLETE PLANT
- 4.PVC RIGID / FLEXIBLE PROFILES
- 5.PVC TRUNKING COMPLETE PLANT
- 6.PS FOAM PICTURE FRAME AND BUILDING / DECORATION PROFILE
- 7.ALL KINDS OF PROFILE DIE

› **ACCESSORIES:**

- 1.MIXER AND COOLER
- 2.PRINTING MACHINE



Everplast Machinery Co.,Ltd

Office:11F., No. 106, Yongle St., Luzhou Dist., New Taipei City 247, Taiwan
TEL. +886-2-2289-7271 FAX. +886-2-2289-7282
Factory:No.151, Yonke S. Rd., Yonkang Dist., Tainan City 710, Taiwan
TEL. +886-6-201-4846 FAX. +886-6-201-4290
E-mail:everstar@mail.everplast.net
www.everplast.com.tw